

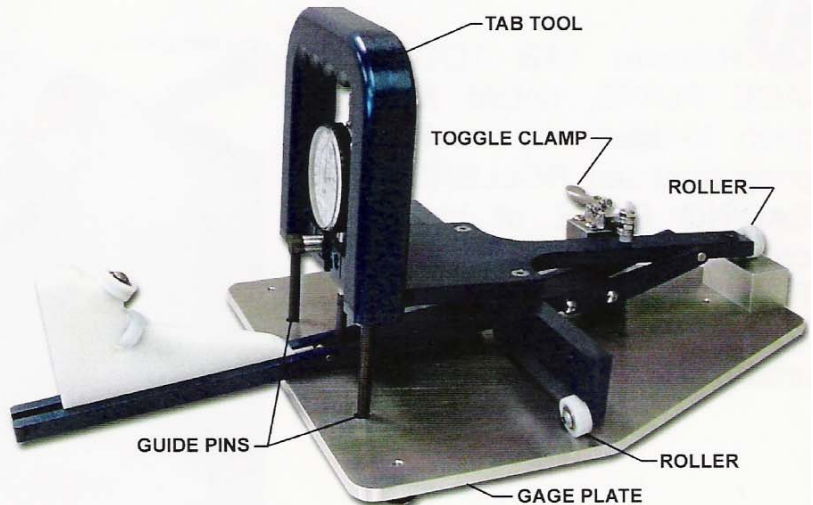

MUNSCH & COMPANY AEROMECHANICS

1 Place folded TAB TOOL on GAGE PLATE making sure GUIDE PINS are inserted into the alignment holes and all three ROLLERS are resting on the GAGE PLATE. Clamp the TAB TOOL in place by pushing down on the TOGGLE CLAMP arm.



AH-64

2 Loosen the THUMB SCREW and slide INDICATOR so that the small pointer reads "0" and the large pointer reads 0°. Tighten the THUMB SCREW. To make fine adjustments, loosen the SMALL THUMB SCREW on top of the INDICATOR and turn the dial face so that the pointer reads 0°.

TRIM-TAB TOOL

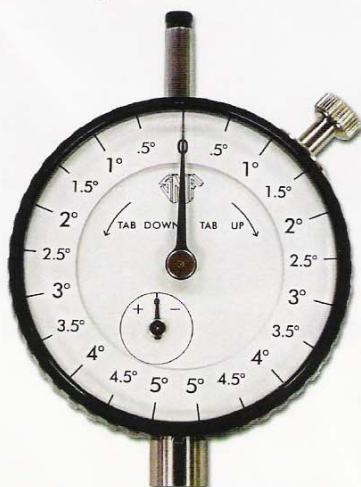
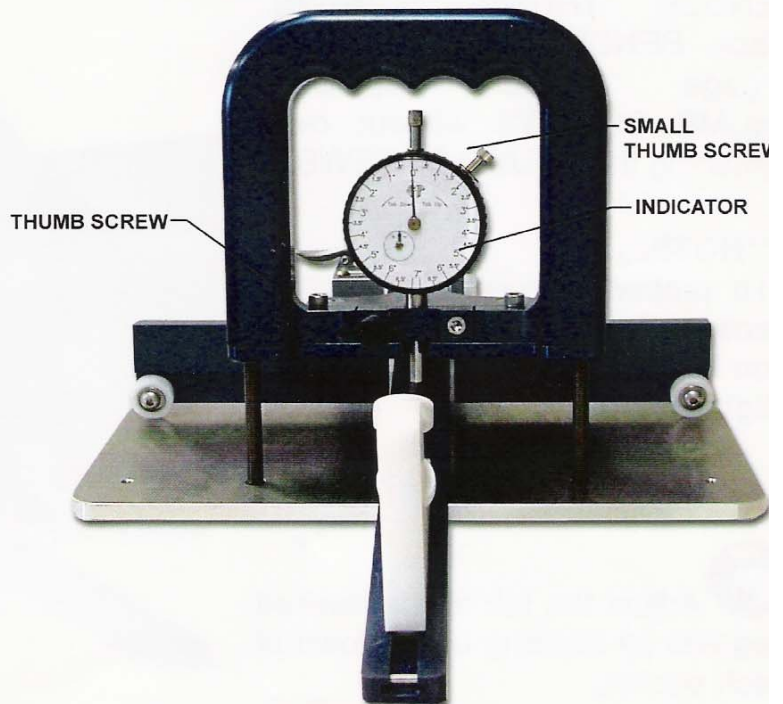

DIAL INDICATOR

**3708 MacGregor Drive
Com. 803-738-9575**

**Columbia, SC 29206 USA
Cell. 803-360-2008**

3 Remove TAB TOOL from GAGE PLATE, unfold arm and attach to blade by hooking the spring mounted ROLLERS to the LEADING EDGE of blade and hooking the two GUIDE PINS on TRAILING EDGE of tab. INDICATOR tip should rest on top surface of tab.

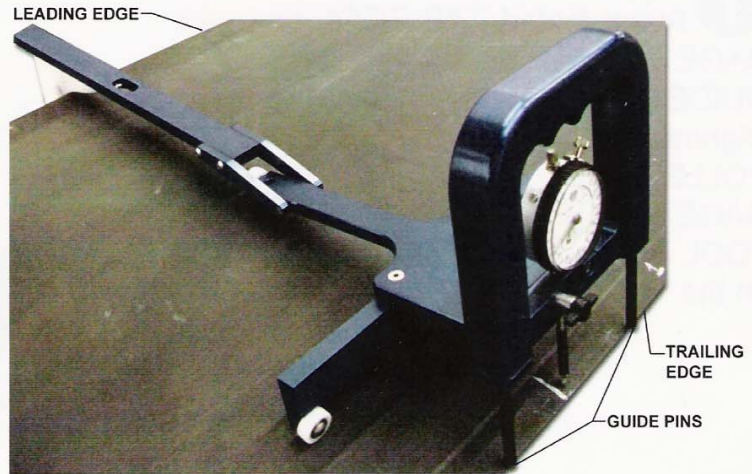

4 Roll TAB TOOL to the desired blade pocket requiring adjustment. Loosen the two BENDER THUMB SCREWS. Place BENDER on the tab to engage. Tighten BENDER THUMB SCREWS without over tightening the THUMB SCREWS.

****NOTE:**

To properly measure a pocket, ensure TAB BENDER is inserted on blade with THUMB SCREWS tightened as shown.

5 Adjust the tab to the desired degrees by bending up or down at each pocket.

